

Panasonic®

Operating Instructions Installation Instructions

Electric Built-in Oven



FOR DOMESTIC USE ONLY

Model No. HL-CK614S

IMPORTANT SAFETY INSTRUCTIONS: Before operating this oven, please read these instructions carefully and keep for future reference.

- This appliance can be used by children aged from 8 years and above and persons with reduced physical, sensory or mental capabilities or lack of experience and knowledge if they have been given supervision or instruction concerning use of the appliance in a safe way and understand the hazards involved. Children shall not play with the appliance. Cleaning and user maintenance shall not be made by children without supervision.
- **WARNING:** The appliance and its accessible parts become hot during use. Care should be taken to avoid touching heating elements. Children less than 8 years of age shall be kept away unless continuously supervised.
- **WARNING:** Danger of fire: do not store items on the cooking surfaces.
- **WARNING:** Ensure that the appliance is switched off before replacing lamp to avoid the possibility of electric shock.
- Do not use harsh abrasive cleaners or sharp metal scrapers to clean the oven door glass since they can scratch the surface, which may result in shattering of the glass.
- Do not use steam cleaners or high-pressure cleaners to clean the cooking appliance, as this may result in an electric shock.

Contents

Important safety instructions.....	5-7
Outline diagram	8-9
Operation modes	10-11
Before using your oven.....	12
Using your oven.....	13-16
Accessories	16-17
Food preparation	18-27
Cleaning and maintenance.....	28-33
Questions and answers.....	34-35
Installation and connection.....	35-38
Technical Specifications	39

Thank you for purchasing a Panasonic electric oven.

Important safety instructions

This manual constitutes an integral part of the appliance. It should be kept intact and at hand for the appliance's entire life cycle. It is important to carefully read this manual and all of the instructions contained herein before using the appliance.

Installation and Connection

Examine your oven

Please make sure the appliance was supplied to you undamaged. Remove all packaging and examine the oven for any damage such as dents, broken door latches or cracks in the door. If you find any damage, notify your dealer immediately. Do not install a damaged oven.

WARNING



Remove all internal and external packaging. Please ensure all internal packaging is removed before switching the oven on.

Identification label

The identification label indicating the basic information of the appliance is attached to the inside of the oven and is visible when you open the door. (see page 8). Do not remove the label.

Examine your oven

WARNING



Only a qualified electrician may connect the appliance.

Oven connection should be carried out in compliance with the instructions in the section "Connection to the power mains" (pg 37), and the relevant effective regulations and standards.

The appliance must be properly earthed for personal safety.

WARNING



You will lose your warranty entitlement in the event of any damage caused by incorrect installation.

Servicing and Repairs

Servicing and repairs should only be carried out by a qualified electrician. If the appliance is defective, disconnect from mains or switch off the appliance at the circuit breaker in the fuse box. Contact the nearest authorised dealer.

Sprays, aerosols and inflammable substances

Spray canisters, aerosols and other inflammable substances can ignite when heated. Do not store or use such item near the oven.

Important safety instructions

WARNING



The appliance is intended solely for cooking. Do not use it for any other purpose, e.g. for room heating.

Improper Use

Do not place empty cookware inside the oven.

Never obstruct the openings and slits provided for ventilation and heat dispersal.

Do not rest any weight or sit on the open door of the appliance.

To avoid a short circuit, ensure that the power cords of appliances located near this appliance are not caught in the oven door.

Do not use sealed tins or containers in the appliance. Overpressure may occur inside the containers during cooking, creating a danger of explosion.

Do not leave the appliance unattended during cooking processes where fats or oils could be released. Fats and oils may catch fire.

Do not cover the bottom of the oven with aluminium or tinfoil sheets during cooking and do not place pans or trays on it to avoid damage to the enamelled surface.

Do not attempt to tamper with or make any adjustments or repairs to the door, control panel housing, safety interlock switches or any other part of the oven. Repairs should only be carried out by service technicians authorised by the appliance manufacturer.

All cooking operations must take place with the door closed.

Risk of Burns

The appliance becomes very hot during use. Suitable heat-proof gloves should always be worn.

Never prepare food containing high alcohol content. Alcoholic vapours can catch fire in the oven cavity.

WARNING



The manufacturer cannot be held liable for damage to persons or items caused by failure to observe the above instructions, by interference with any part of the appliance or by the use of non-original spare parts.

Important safety instructions



Information on Disposal for Users of Waste Electrical & Electronic Equipment (private households)

This symbol on the products and/or accompanying documents means that used electrical and electronic products should not be mixed with general household waste.

For proper treatment, recovery and recycling, please take these products to designated collection points, where they will be accepted on a free of charge basis. Alternatively, in some countries you may be able to return your products to your local retailer upon the purchase of an equivalent new product.

Disposing of this product correctly will help to save valuable resources and prevent any potential negative effects on human health and the environment which could otherwise arise from inappropriate waste handling. Please contact your local authority for further details of your nearest designated collection point.

Penalties may be applicable for incorrect disposal of this waste, in accordance with national legislation.

Information on Disposal in other Countries outside the European Union

This symbol is only valid in the European Union.

If you wish to discard this product, please contact your local authorities or dealer and ask for the correct method of disposal.

Outline diagram

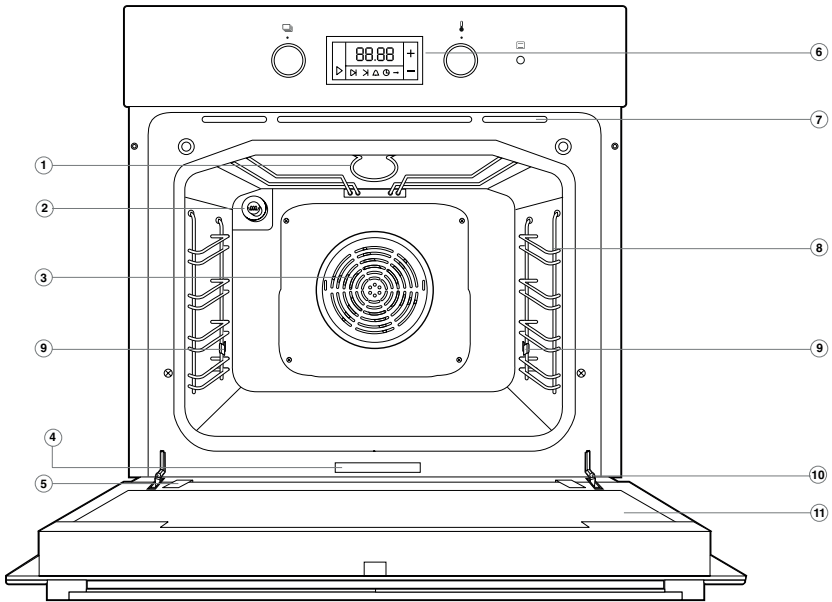

- 1. Grill elements
- 2. Oven lamp
- 3. Oven fan
- 4. Identification label
- 5. Door glass release

- 6. Control Panel
- 7. Air vents
- 8. Shelving guides
- 9. Shelving clips
- 10. Door hinge
- 11. Door glass

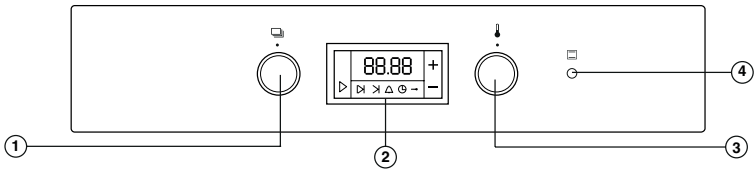

- 1 On/Off and function dial
- 2 Program timer (see page 13)
- 3 Temperature dial

4 Temperature indicator light. The light is on until the set temperature is reached.

This illustration is for reference only.

Operation dials

The oven is operated by the function and the temperature dials.

- Push the dial slightly, to make it pop out of the control panel. After use press it back into its recessed position, flush with the control panel.



The recessed dial may only be pushed back into its recessed position when it is in the "off" position.

On/off and function dial.

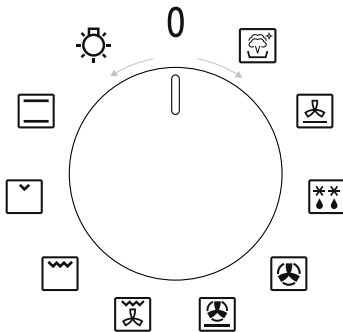

Temperature dial

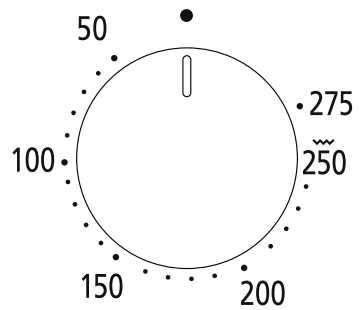

Note: When using the Full grill  or Half grill , set the temperature selection dial to the position indicated .

Operation modes



Oven lighting

There is one interior lighting lamp: on the upper part of the back wall. Oven lighting can be selected independently. With all other modes of operation, the oven lighting is turned on automatically when the operation mode is selected.



Upper / lower heater

The heaters on the upper and lower side of the oven radiate uniformly and evenly into the oven interior. Pastries, cakes and meat can be cooked on one shelf level only.



Full grill

The inner and the outer heaters are activated simultaneously. This operation mode is appropriate for cooking smaller pieces of meat, such as steaks, roasts, chops, ribs, etc.



Half grill

The inner heater is activated. This mode is appropriate for grilling smaller quantities of toasted sandwiches, sausages or bread.

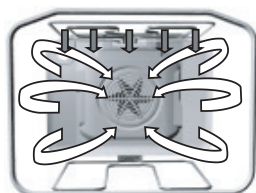

Fan grill

The upper heater and the fan are activated simultaneously. It is appropriate for grilling and browning large pieces of meat, poultry or gratins on one shelf level.

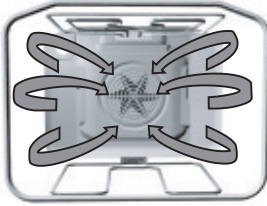

Convection

The back heater and the fan operate simultaneously in order for the hot air to circulate constantly. This mode is appropriate for roasting meat and making pastry on several shelves simultaneously. Cooking temperature should be set lower than conventional operation.

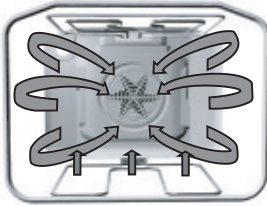

Convection and lower heater

The back heater, the fan and the lower heater operate simultaneously. This is suitable for making pizza, pastries, fruit cakes or baked cheesecakes.

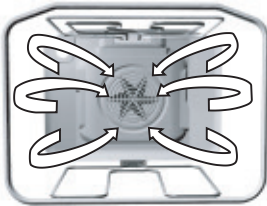

Defrosting

The air is circulated without any heater being turned on. Only the fan is in operation. This is used for defrosting frozen food.

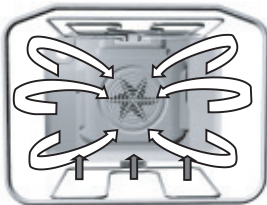

Lower heater and fan

The lower heater and the fan operate simultaneously. Used for baking sweet bread dough and preserving fruit and vegetables. Use the first shelf position from the bottom and shallow rather than deep baking trays.



Lower heater/ Steam clean

The bottom heater is activated. Select this mode when you wish to cook the bottom side of the dish more thoroughly (e.g. for deep pastry with fruit filling). Set the temperature with the temperature selection dial. The lower heater can also be used for cleaning the oven, for instructions please see the "Cleaning and maintenance" section on page 28.

Before using your oven

- Before using the oven for the first time, run Convection at 250 C for 5 minutes. A specific odour of a “new appliance” will be present. Make sure the room is ventilated.
- After the oven has cooled down, clean the inside and all accessories with warm water and a conventional detergent. Do not use abrasive cleaning aids.

Important warnings

- Use dark, black silicon coated or enamel coated baking trays, as these transmit the heat well.
- Only preheat the oven if specifically stated in the recipe or in the cooking charts supplied.

Note

Cooling fan

The appliance features a built-in cooling fan which cools the appliance housing and control panel.

- **Note:** Whilst cooking the oven may have a build up of steam. To cool the oven and remove the steam, set the function dial to  to turn on the fan.

Using your oven

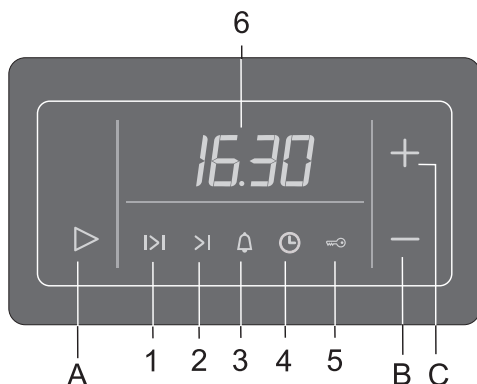

Operation keys:

- A** Function selection and confirmation key
- B** Minus key
- C** Plus key

Display:

- 1** Duration/ cooking timer
- 2** Program end time
- 3** Kitchen timer
- 4** Clock
- 5** Child lock
- 6** Clock / time display

- When the appliance is connected to the power supply or after a power failure, the word “META” is first displayed; then, the display flashes. To enable operation of the oven the time must be set using **+** and **-**.

Setting the clock

- Press the **▷** key until the **🕒** is selected.
- Press the **+** and **-** key to set the time of day.
- Confirm the setting by pressing the **▷** key again; if the **▷** key is not pressed, the time will automatically set after a few seconds.
- This is a 24 hour clock.

Selecting timer functions

- Select the type of function required by pressing the **▷** key. The selected function will flash for five seconds, the value can be set during this time. Once set, the function will flash slowly and the time is displayed. N.B. The symbols lit are selected. The most recent setting will be shown in the display.
- Each press of a key is acknowledged by a beep.
- If one of the value settings keys **+** or **-** is touched and held, the speed of changing the value will increase.
- In case of a power failure which lasts less than two minutes, all settings are maintained.

⚠ To improve the response of the keys, touch them with a larger surface of your finger.

Manually setting the oven

- Select the operation mode using the function dial (see page 9).
- Set the required temperature using the temperature dial (see page 9. After each use, turn the dials back to the off position).

Using the timer

Setting the duration/ cooking time

This mode allows you to set a function for a specific length of time. A maximum of 10 hours can be set.

- Press the ▷ key to select the symbol |>|. Use the + and — keys to set the duration / cooking time.
- Use the oven dials to set the operation mode and temperature. When the set time has elapsed, the oven will automatically stop operating. An intermittent beep will sound, which can be stopped by pressing any key; if no key is pressed, the beep will stop after one minute.
- To edit the time set, press ▷. Use the + and — keys to modify.
- After cooking, the symbol |>| and the sign (-.-) will flash. Turn the dials to zero, or if you wish to resume cooking, press and hold the ▷ key to set a new duration/ cooking time.
- To return to the clock press and hold + and — for 3 seconds.

Setting the program end time

This mode allows you to set the time at which the oven should stop operating. A maximum of 10 hours relative to the current time of day can be set.

- Make sure the current time of day is set correctly.
- Use the ▷ key to select >|. The current time of day is indicated on the display. Press the + and — keys to set the program end time.
- Use the oven dials to set the operation mode and temperature. When the set time has elapsed, the oven will automatically stop operating. An intermittent beep will sound, which can be stopped by pressing any key; if no key is pressed, the beep will stop after one minute.
- During cooking, the program end time will be displayed.
- To edit the time set, press ▷. Use the + and — keys to modify.
- After cooking, the symbol |>| and the sign (-.-) will flash. Turn the dials to zero, or if you wish to resume cooking, press and hold the ▷ key to set a new duration/ cooking time.
- To return to the clock press and hold + and — for 3 seconds.

Setting the delayed start

With this operation mode, two settings have to be made: duration/ cooking time and cooking end time.

Cooking end time can be delayed by a maximum of 24 hours relative to the current time of day.

- Make sure the current time of day is set correctly.
- First, set the duration/ cooking time: Press the ▷ key to select the symbol |>|. Use the + and — keys to set the duration / cooking time.
- Then, set the cooking end time: Use the ▷ key and select the symbol >|. Press the + and — keys to set the program end time. (A sum of the current time of day and the oven operation time is automatically shown on the display).
- Use the function dial to select the operation mode and the temperature dial to select the required temperature.
- Both symbols |>| and >| are lit. When cooking begins only the symbol |>| will be displayed.

- When the set time has elapsed, the oven will automatically stop operating. An intermittent beep will sound, which can be stopped by pressing any key; if no key is pressed, the beep will stop after one minute.
- To edit the time set, press ▷ . Use the + and — keys to modify.
- After cooking, the symbol |▷| and the sign (-.-) will flash. Turn the dials to zero, or if you wish to resume cooking, press and hold the ▷ key to set a new duration/ cooking time.
- To return to the clock press and hold + and — for 3 seconds.

Setting the kitchen timer

The oven has a kitchen timer that sounds an alarm after counting down the preset time.

- Use the ▷ key to select the symbol ⏰ . Then, use the + and — keys to set the time before the alarm sounds. Maximum time 10 hours.
- When the set time has elapsed, an intermittent beep will sound and the symbol ⏰ flashes, which can be stopped by pressing any key; if no key is pressed, the beep stops after one minute.

N.B. The last minute of the timer countdown is displayed in second intervals.

Setting the beep volume

The alarm volume can be set when no timer function is activated (only current time of day is displayed).

- Press the — key and hold it approximately three seconds; a volume indicator will appear, and the corresponding sample sound will sound. “oooo” indicates maximum volume, and “o” indicates minimum volume. Use the — key to select among the four volume levels.
- Confirm the selected volume level by pressing the ▷ key; if the ▷ key is not pressed, the setting will be confirmed and stored automatically after a few seconds.

Setting the child lock

The display may be locked only after one of the time functions has been set (period of operation, end of operation, or alarm.) The oven will function normally, but you will not be able to change the timer settings.

Activation: Press the ▷ key to select the symbol 🔒 . Use the + or — keys to activate the child lock; the display will read “ON”. Confirm the setting by pressing the ▷ key. The 🔒 symbol is lit when activated.

Deactivation: Press the ▷ key to select child lock, then press the + or — to deactivate the child lock; “OFF” is displayed. The setting must be confirmed by pressing the ▷ key.

Deleting the timer settings

- All timer settings can be deleted at any time by pressing the + and — keys simultaneously and holding them for three seconds. The set programs are automatically interrupted and the timer switches to display the current time of day.
- Another way to delete a setting is by setting the timer value to “0.00”.

Shelf levels

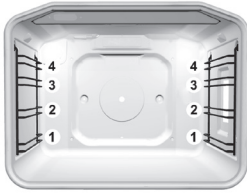

- Accessories (wire shelf, shallow baking tray and the deep baking tray) can be inserted into the oven at four levels.
- Please note that the shelf levels are always referred to by consecutive numbers starting from the bottom (particular shelf levels are described in the cooking tables)
- The wire shelf and the trays should always be inserted into the main slot formed by the wire guides.

Accessories



Wire shelf

Food is placed directly on wire shelf or in a container on wire shelf.



A safety stop is fitted on the wire shelf and on the guides. To pull out the wire shelf, lift it slightly when it hits the stop.

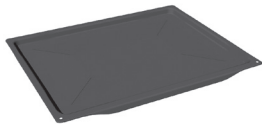

Shallow baking tray

This is used for baking pastry, cakes and biscuits.

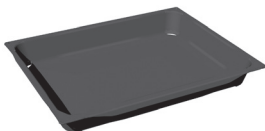

Deep baking tray

This is used for roasting meat and as a drip tray.



The deep baking tray is used only as a drip tray when using the grill functions, the deep tray should not be inserted into the fourth shelf position.

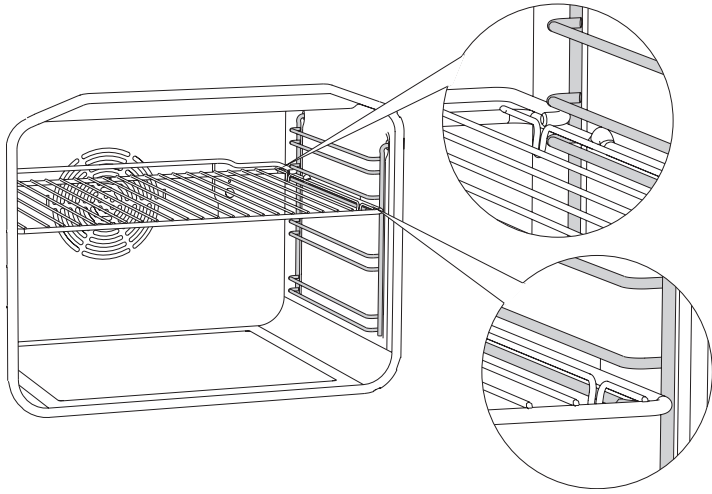

- Place the wire shelf, deep baking tray, or shallow baking tray on the guides and push it into the oven. Close the oven door only when the accessories have been fully inserted.



The fan on the oven back plate is covered by a catalytic layer that can be installed or removed only by an authorised service technician.

Baking and Cooking

- Use the ,  or  mode of operation.

Instructions

- Always observe the instructions on the shelf / shelf position, temperature, and cooking time indicated in the baking table. The values indicated in the table are defined and checked especially for this particular oven.
- If the baking table does not specifically mention a particular food, refer to the information for a similar type of food.



Cooking / baking with upper and lower heater

- Cook / bake at one level only.
- Upper / lower heater combination is suitable for cooking various types of pastry, bread, and meat.
- Use dark-coloured baking trays. Light-coloured trays reflect the heat, which leads to poorer cooking (browning) results. Always place your own cooking containers on the wire shelf. If you are using the supplied baking tray, remove the wire shelf.
- Preheating will shorten the cooking time. Place the dish into the oven only when the selected temperature has been reached, i.e. When the control lamp goes off for the first time.

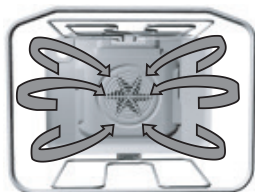

Cooking / baking with convection

Cooking / baking with hot air is useful when you wish to bake on several shelves simultaneously. Preheating is recommended. This mode is also appropriate for large sponge cakes and fruit cakes (in this case, bake on a single level only).

- The temperature is normally set lower than when baking with the upper/lower heater combination (see baking table).
- When baking with several baking trays simultaneously, baking time for each tray can vary. You may have to remove one of the trays earlier (normally, this would be the uppermost tray).
- When using several baking trays simultaneously, there may be a significant amount of vapour in the oven, resulting in condensation on the oven door.

Tips on baking

Is the cake cooked?

At the end of the cooking time, insert a metal skewer into the highest point of the cake and then withdraw it. If the batter does not stick to the metal skewer, the cake is cooked. Some recipes recommend to turn off the oven and use the remaining accumulated heat.

The sponge cake has collapsed

Check the recipe. Check the instructions relating to mixing time. Ensure the oven door is not opened during cooking.

The pastry is too light-coloured

A dark-coloured baking tray, cooks dishes faster and browns foods more than lighter coloured pans. Place the tray one shelf position lower, or turn on the lower heater towards the end of the cooking process.

Pastries with a moist filling (e.g. deep filled pie) not cooked.

Reduce the temperature and extend the cooking time.

Notes on the baking chart:

- Two values are indicated for temperature, lower and upper. Initially, set the lower temperature; if the pastry is not brown enough, increase the temperature.
- Cooking times are a guideline only.
- The value printed in bold in the temperature table indicates the most appropriate operating mode for a particular type of food.
- Always preheat the oven.
- When using baking paper, make sure it is resistant to high temperature.

Baking chart for combined upper and lower heater or convection mode - one level cooking only



Food	Shelf position (from the bottom)	Temperature (°C)	Shelf position (from the bottom)	Temperature (°C)	Cooking time (minutes)
Cakes and desserts					
Marble cake, ring cake	1	160-170	1	150-160	45-60
Tray bake cake	1	160-170	1	150-160	40-50
Sponge cake in round tin	1	160-170	2	150-160	45-60
Baked cheesecake	1	170-180	2	150-160	50-60
Fruit pie	1	180-190	2	160-170	30-50
Fruit cake	2	170-180	2	150-160	45-65
Swiss roll	2	180-190	2	160-170	15-25
Sweet bread dough	2	170-180	2	160-170	20-25
Christmas cake	2	170-180	2	150-160	120-150
Apple pie	2	180-200	2	170-180	40-60
Baked donuts	1	170-180	2	150-160	20-30
Cookies	2	160-170	2	150-160	15-25
Meringue nests	2	110	2	100	75-115
Eclairs	2	180-190	2	180-190	15-25
Savoury pastry and bread					
Quiche Lorraine	1	190-210	2	170-180	50-65
Pizza	2	210-230	2	190-210	25-45
Bread	2	190-210	2	170-180	50-60
Bread rolls	2	200-220	2	180-190	30-40
Savoury cheese strudel	2	190-200	2	180-190	25-30
Vol-au-vents	2	190-200	2	170-180	15-20
Soufflés					
Cheese soufflé	1	190-200	2	180-190	25-30
Frozen food items					
Apple pie	2	180-200	2	170-180	50-70
Cheesecake	2	180-190	2	160-170	50-60
Pizza	2	200-220	2	170-180	20-30
Oven chips	2	200-220	2	170-180	20-35
Croquettes	2	200-220	2	170-180	20-35

Note: Shelf position refers to the wire shelf onto which baking trays or cake tins are placed, and to shallow baking tray. The deep baking tray should not be inserted into the first shelf position. The value printed in bold in the temperature table indicates the most appropriate operating mode for a particular type of food.

Baking chart with convection and lower heater

Food	Shelf position (from the bottom)	Temperature (°C) 	Cooking time (minutes)
Cheesecake - large	2	150-160	50-60
Pizza	2	200-210	15-20
Quiche Lorraine	2	180-200	35-40
Apple pie	2	150-160	35-40
Fruit cake	2	150-160	45-55
Apple pie - puff pastry	2	170-180	45-65

Cooking / roasting meat and fish

- To cook meat or fish, use the operating modes  or .
- Data printed in bold represent the most appropriate operation mode for a particular type of meat and fish.

Tips on using the cookware

- Meat and fish can be cooked in enamel coated cookware, ovenproof glass (Pyrex®) cookware, clay, or cast iron cookware.
- Stainless steel baking trays are less appropriate because they reflect the heat.
- If the roast is covered, it will remain juicier, and the oven remains cleaner.
- In an uncovered baking tray, the roast will brown quicker.

Some notes on cooking meat

- The meat cooking table indicates recommended temperatures, shelf position, and cooking time. Since cooking times depend strongly on the type, quantity, weight, and quality of meat, they may have to be adjusted.
- When cooking meat, add enough liquid to prevent the meat drying out. With longer cooking times, the roast should be checked and more liquid added if necessary.
- When roasting larger joints of meat, condensation may accumulate on the oven door. This is normal and does not affect the operation of the appliance. After cooking, wipe the area dry.

Meat and fish cooking chart for upper/lower heater combination or with hot air - one level cooking only

Type of meat	Weight (g)	Shelf position (from bottom)	Temperature (°C) □	Shelf position (from bottom)	Temperature (°C) ⊗	Cooking time (min.)
Beef						
Beef roast	1000	2	190-210	2	180-190	100-120
Beef roast	1500	2	190-210	2	170-180	120-150
Roast beef, medium done	1000	2	200-210	2	180-200	30-50
Roast beef, well done	1000	2	200-210	2	180-200	40-60
Pork						
Pork roast, with skin	1500	2	180-190	2	170-180	140-160
Pork belly	1500	2	190-200	2	170-180	120-150
Pork belly	2000	2	180-200	2	160-170	150-180
Shoulder	1500	2	190-200	2	160-170	120-140
Pork roll	1500	2	190-200	2	160-170	120-140
Cutlet	1500	2	180-200	2	160-170	100-120
Pork meatloaf	1500	2	200-210	2	170-180	60-70
Veal						
Veal roll	1500	2	180-200	2	170-190	90-120
Veal joint	1700	2	180-200	2	170-180	120-130
Lamb						
Lamb loin	1500	2	190-200	2	170-180	100-120
Roast leg	2000	2	190-200	2	180-190	60-120
Shoulder	2500	2	180-190	2	170-180	180-210
Neck	800	2	190-200	2	180-190	90-120
Game						
Venison shoulder	2500	2	190-200	2	180-190	90-100
Poultry						
Chicken, whole	1200	2	190-200	2	180-190	60-80
Chicken, whole	1500	2	190-200	2	180-190	70-90
Duck	1700	2	180-190	2	160-170	120-150
Goose	4000	2	160-170	2	150-160	180-200
Turkey	5000	2	150-160	2	140-150	180-240
Fish						
Whole fish	1000	2	190-200	2	170-180	50-60
Fish fillet pieces	1200	2	180-200	2	170-180	20-30

Note: Shelf position refers to the deep tray; smaller trays should be placed on the wire shelf in the first or second shelf position. Do not place the deep tray in the fourth shelf position. The value printed in bold in the temperature table indicates the most appropriate operating mode for a particular type of food.













Grilling and browning

- Take care when grilling meat. Always use oven gloves when removing the food and accessories after grilling as the oven and accessories will be very hot. Use meat tongs to turn the meat.
- Check the grilling meat regularly. Do not leave unattended.
- Do not allow children near the grill.
- Grilling is recommended for meat pieces and fish (steak, chops, salmon fillets, etc.) toasting bread and browning gratins.

Some tips on using the grill function

- When using the grill, oven door should always be closed.
- The cooking chart for grilling indicates recommended temperature, shelf position, and cooking time. Since cooking time depends strongly on the type, quantity, weight, and quality of meat, it may have to be adjusted.
- It is recommended to preheat the grill.
- Place thin slices of meat on the wire shelf and place it into the fourth shelf position.
- Insert a baking tray, which will serve as a drip tray in this case, into the first or second shelf position to collect the dripping fat and meat juices.
- Cook the first side longer than the second side.
- When grilling larger pieces of meat (e.g chicken) and fish on the wire shelf, insert the wire shelf into the second shelf position and the drip tray into the first shelf position.
- Thinner slices of meat should only be turned once, while the thicker ones should be turned several times.
- After using the grill, clean the oven and accessories.









Cooking chart - Large grill

Type of food	Weight (g)	shelf position (from bottom)	Temperature (°C)	Temperature (°C)	Cooking time (min)
Meat / poultry (with wire shelf)					
4 beef steaks, rare	180/pc	4	Level 	-	14-16
4 beef steaks, medium	"	4		-	16-20
4 beef steaks, well done	"	4		-	18-21
4 pork chops	"	4		-	19-23
4 pork cutlets	"	4		-	20-24
4 veal steaks	"	4		-	19-22
6 lamb cutlets	100/pc	4		-	15-19
8 grill sausages	100/pc	4		-	11-14
1/2 chicken	600	2	-	180-190	25 (side 1) 20 (side 2)
Whole chicken	1500	2	210-220	160-170	60-85
Meat (with deep baking tray)					
Duck	2000	2	210	150-170	80-100
Pork roast	1500	2	-	150-160	90-120
Pork shoulder	1500	2	-	150-160	120-160
Pork joint	1000	2	-	150-160	120-140
Roast beef	1500	2	-	170-180	40-80
Fish					
Salmon fillets	600	3		-	19-22
4 whole trout	200/pc	2	-	170-180	45-50
Toasted bread					
6 slices, white bread	/	4		-	5 (side 1) 3 (side 2)
4 slices, wholegrain bread	/	4		-	2-3
Toasted sandwich	/	4		-	5 (side 1) 7 (side 2)
Gratin*					
Cauliflower	750	2	-	210-230	15-25
Potato	750	2	-	210-230	25-30

Note: When slow roasting meat in a tray, make sure there is enough liquid in the tray to prevent the meat from burning. When grilling meat on the wire shelf, insert the deep tray into the first or second shelf position and this can be used as a drip tray (see tips on grilling meat).

* **Recommendation:** Vegetables are first partly cooked and covered in béchamel sauce and grated cheese. Use a small glass baking dish and place it on the wire shelf.

Cooking chart - Half grill and fan grill

Food type	Weight (g)	Shelf position (from bottom)	Temperature (°C) 	Temperature (°C) 	Cooking time (min.) 
Meat and sausages					
2 beef steaks, well done	180g/pc	4	Level 	-	18-21
2 lamb cutlets		4		-	20-22
2 pork steaks	180g/pc	4			18-22
4 grill sausages	100g/pc	4		-	11-14
4 toasted sandwiches		4		-	5-7
Toast - browning		4			3-4
3 whole trout - on the wire shelf	200g/pc	2	-	160-170	40-50
Chicken - on the wire shelf	1500g	2	-	160-170	60-80
Pork shoulder - deep tray	1500g	2	-	150-160	120-160

Defrosting

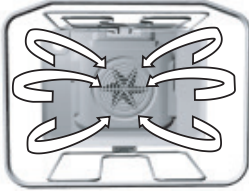

- Air circulating in the oven may speed up the process of defrosting frozen food. To do this, set the oven to  mode.

 ***If the temperature setting button is accidentally activated, the oven control lamp will illuminate, but the heaters will not be activated.***

- Food appropriate for defrosting includes cakes with cream or butter cream filling, other cakes and pastry, bread, buns, and deep-frozen fruit.
- For hygiene reasons, meat and poultry should not be defrosted in an oven.
If possible, turn the food around to make sure it is defrosted evenly.

Cleaning and maintenance

Do not use a steam cleaner or a high-pressure steam cleaner to clean the appliance. Before cleaning the appliance, disconnect it from the power mains and allow to cool down.

Appliance housing front

Clean the surfaces with non-abrasive detergents, and a soft cloth. Apply the detergent on the cloth and wipe off the dirt; then, rinse with water. Do not apply the detergent directly on the surfaces. Do not use abrasive cleaners, sharp objects or steel wool, as these will scratch the appliance.

Door handle

The door handle should be cleaned with non-abrasive detergent. Apply the detergent on a wet cloth and clean the surface; then, rinse the surface with water. Do not apply the cleaner directly onto the surface. Do not use abrasive cleaners or abrasive sponges. The surface should not come into contact with oven cleaning sprays.

Stainless steel front panels

Clean the surface with a mild cleaner and a soft sponge that will not scratch the material. Do not use abrasive or solvent-based cleaners. If these instructions are ignored, the housing surface may become damaged.

Lacquer-coated and plastic surfaces

Clean the dials with a soft cloth and liquid detergents. You may also use branded cleaners; in this case, follow the manufacturer's instructions.

WARNING: The above surfaces should never come into contact with oven cleaning sprays, as these may cause permanent damage.

Cleaning

Oven

- The oven can be cleaned in a conventional manner (with detergents, oven spray), but only use on stubborn stains.

Steam clean function

- For regular cleaning of your oven, the following procedure is recommended: rotate the operation mode selection dial to the position . Set the temperature selection dial to 70°C. Pour 0.6 litre of water into deep baking tray and insert it into the first shelf position. After thirty minutes, the food residues on the enamel will have softened, allowing you to wipe them with a damp cloth.

When dealing with stubborn stains:

The oven should be cooled down before each cleaning process.

- Clean the oven and accessories after each use to prevent the dirt from being burnt onto the oven.
- The easiest way to remove grease is by using warm soapsuds while the oven is still warm.
- In case of stubborn dirt, use the conventional oven cleaners. Then, rinse the oven thoroughly with clean water to remove all residues of the cleaner.
- Never use abrasive cleaners such as steel wool, abrasive dish washing sponges, stain removers, etc.
- Oven cleaning sprays should never be used to clean the grill elements.
- When purchasing and dispensing detergents, observe the instructions provided by the manufacturers.

Catalytic layer on the back plate

- Catalytic enamel is soft and sensitive to mechanical stress; therefore, the use of abrasive cleaners and sharp objects is not recommended.
- Coarse catalytic enamel speeds up the disintegration of grease and spills. Minor stains that remain after cooking normally disintegrate. In general, the stains will disappear at temperatures above 220°C.

Practical tip

- When cooking larger fatty pieces of meat or poultry, we recommend covering them in aluminum foil, to prevent the grease from being spattered on the oven interior walls.
- When grilling meat on the wire shelf, place a drip tray underneath.

Accessories

Wash the accessories (baking trays and wire shelf) with hot water and some conventional detergent.

Special enamel coating

The oven, interior side of the door, and baking trays, are covered with special enamel that has a smooth and resistant surface. This special layer enables easier cleaning at room temperature.

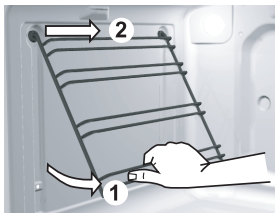

Removing wire guide racks

To facilitate cleaning of the oven interior side walls, the wire guide rack can be removed.

- The guide rack is held in place by a clip. To remove the guide rack, hold it by the lower end and pull towards the center of the oven (fig 1). Make sure that the guide has been released from both clips then rotate inwards (fig 2) to remove from the side of the oven.
- Only clean with conventional cleaners.
- After cleaning, re-hang the guide racks and clip back into place.

REMOVING AND REPLACING THE OVEN DOOR

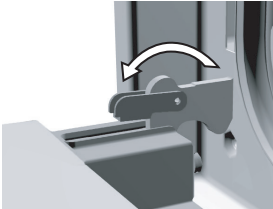

Figure 1

- Fully open the oven door and rotate the stoppers all the way back (Figure 1).

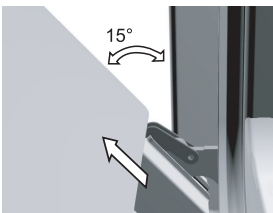

Figure 2

- Slowly close the door until the clips are pressed against the supports. At approximately 15° (relative to the closed door position), pull the door slightly upward and pull them out from both hinge supports on the appliances (Figure 2).
- Replace the door in the reverse order. Insert the door under an angle of 15° into the hinge supports at the front side of the appliance and push them downwards to the front until they slide into their supports.
- Then, completely open the door and rotate the attachment clips back to their initial position. Slowly close the door and check, if they close properly. If the door does not open or close correctly, ensure the hinge notches are correctly placed in their hinges.

Attention

Always ensure the hinge attachment clips are secured in their supports when installing the door. Otherwise, the main hinge that is operated by a strong spring may be released while installing or removing the door and there is a risk of physical injury.

REMOVING INSIDE DOOR GLASS

Door glass can also be cleaned from the interior side; the door has to be removed first (see section on removing and replacing the oven door).

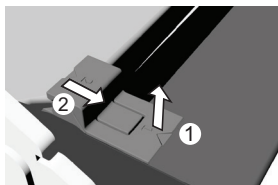

Figure 1

- Slightly lift the supports on the left and right side of the door (marking 1 on the support) and pull them away from the glass (marking 2 on the support) (see Figure 1). replacing the oven door).

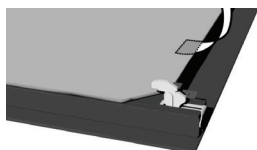

Figure 2

- Hold the door glass by the lower edge, slightly lift it so that it is no longer attached to the support, and remove it (Figure 2).



Figure 3

- To remove the third inside glass, lift and remove it. Also remove the rubbers on the glass (Figure 3).

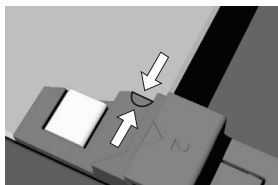
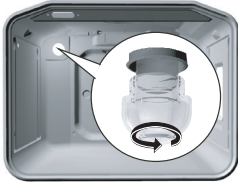

Figure 4

- To replace the door, observe the reverse order.
Note: To replace the glass, make sure the markings (crescent) on the door and the glass are aligned (Figure 4).

Replacing the oven bulb



The oven lamp base and socket are under voltage. There is a risk of electric shock!

Before replacing the oven bulb, disconnect the appliance from the power mains by removing the fuses or tripping the main network switch.

Oven bulb

The oven bulb is considered a replacement spare part and is not covered by the warranty. Replace the bulb with a new one with the following specifications: socket E 14, 230 V, 25 W, 300°C.

- Unscrew the glass cover in an anticlockwise direction, replace the bulb, and replace the cover.

Bulb lamps used in this appliance are special purpose lamps selected for household appliances use only. They are not suitable for household room illumination.

Questions and answers

During the warranty period, any repairs may only be performed by service technicians authorised by the appliance manufacturer.

Before starting the repair, the appliance must be disconnected from the power mains by removing the fuse or by removing the mains cord from the wall outlet.

Unauthorised tampering and repairs may cause electric shock and short circuit; do not attempt this yourself. Consult an expert or an authorised service technician.

In case of minor faults or problems with the appliance operation, check the following instructions to see whether you can eliminate the causes by yourself.

Important

A visit by an authorised service technician during the warranty period will be charged if the appliance is not functioning because of improper use. Store these instructions in a place where they are always readily accessible; if passing the appliance on to another person, the instructions should also be included.

Following is some advice on rectifying some common problems.

Touch keys do not respond, the display has frozen	<ul style="list-style-type: none">• Disconnect the cooker from the power mains for a few minutes (remove the fuse or trip the main switch) then reconnect it to the power mains and turn on the oven.
The main fuse keeps tripping	<ul style="list-style-type: none">• Call an authorised service technician!
Oven interior lighting does not work	<ul style="list-style-type: none">• Replace the oven bulb (see page 33).
The oven does not heat up	<ul style="list-style-type: none">• Was the temperature and operating mode selected correctly?• Is the oven door closed?
The cake is not cooked thoroughly	<ul style="list-style-type: none">• Did you follow the instructions and tips from the Baking section? (Refer to pages 18-19).• Did you follow the instructions in the baking chart? (Refer to pages 20-21).
The program timer shows error figures	<ul style="list-style-type: none">• In case of faulty operation of the program timer, disconnect the oven from the power mains for a few minutes (remove the fuse or trip the main switch), then reconnect it to the mains and set the time of day.

Program timer display is blinking	<ul style="list-style-type: none"> • There was a power supply failure, or your cooker was just connected to the power mains. All set times have been deleted. • Set the time of day to enable operation of the appliance. • After the end of program timer controlled operation (automatic operation), the oven goes off, the time of day is displayed, and a beep signal is emitted. Take the dish out of the oven, return the operation mode selection dial and the temperature dial back to the starting position. Select the “Manual mode” function to be able to use the oven in the conventional way (without the program timer).
Temperature indicator light is not lit...	<ul style="list-style-type: none"> • Did the main fuse in your home network trip? • Are the temperature dial and the function dial set properly?

If the problem persists despite observing the instructions above, call an authorised service technician. Warranty claims that resulted from improper connection or use of the appliance is not covered by our warranty. In such cases, the costs of repair are borne by the user.

Instructions for use of the appliance can also be found on our website at www.panasonic.co.uk

Installation and connection

- When performing the installation, these instructions must be followed. Improper installation may cause an electric leakage or fire.
- Install 220-240 V / 16 A dedicated single-phase circuit with earth leakage circuit breaker for the power supply. The electrical wiring may abnormally overheat if the dedicated circuit is not properly connected.
- Electrical work must be performed by a qualified electrician. Improper wire connections may cause electric leakages, fires or electric shock.
- This appliance must be properly earthed following the electrical laws. Earth line must not be connected to gas pipe, water pipe, earth of lightning rod and telephone. Otherwise, it may cause electric shock in case of appliance breakdown or insulation breakdown.
- Before performing the installation, definitely turn off the circuit breaker. This can prevent electric shock.

Installation and connection

Important warnings

⚠ The appliance may only be connected by a qualified electrician.

- The appliance should be fitted with a device that disconnects it from all poles of the home network (an omnipolar switch), with at least 3 mm of distance between the contacts in open position. Miniature circuit breakers or fuses are appropriate.
- To connect the appliance, use the rubber mains cords (type HO5RR-F with the green/yellow earth wire), PVC insulated (type HO5VV-F with the green/yellow earth wire), or other equivalent or superior cables. The cable must be rated at 16 Ampere or greater. The screw terminals can accept conductors between 1.5mm² and 6.0mm².
- Veneer, glue, or plastic finish of the furniture next to which the cooker is installed, should be heat resistant (100°C). If the veneers are not high temperature resistant, they may be damaged.
- Packaging (plastic foil, polystyrene, etc.) must be kept out of reach of children and disposed of in the correct manner. Small parts can be swallowed by children and plastic can pose a risk of suffocation.

Installation

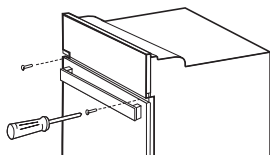

- Veneer or other finish of the furniture the appliance is being built into should be processed with heat-resistant glue (100°C); otherwise, high temperatures may cause them to deform.
- Before installing the appliance, remove the back wall from the piece of kitchen furniture the appliance is being built into, along the entire length of the cutout.
- The installation cutout should be dimensioned as indicated in the figure.
- The bottom panel of the piece of kitchen furniture (Max. 530 mm) should always be shorter than the side walls to enable adequate air circulation.
- Level the piece of furniture the appliance was built into with a spirit level.
- The piece of kitchen furniture the appliance is built into must be secured against movement, e.g. Attached to the adjacent pieces of kitchen furniture.
- Push the appliance into the kitchen furniture enough that the guides for the screws that are inserted in the oven frame holes are placed against the kitchen side walls.
- When attaching the appliance, make sure the screws are not fastened too strongly as this may damage the furniture or the appliance enamel coating.

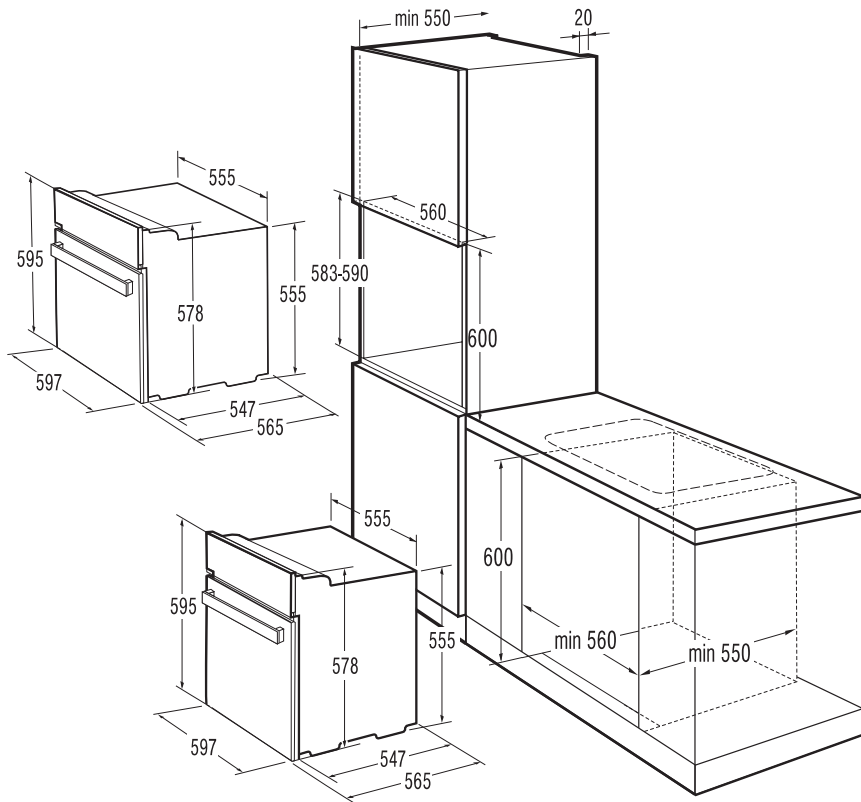

Electrical connection

The appliance may only be connected to the power mains by an authorised service technician or a qualified electrician! Incorrect connection may result in damage to or destruction of respective parts of the appliance; in such cases, the warranty is void.

The appliances are suitable for photovoltaic electrical power under the condition that electrical voltage will be 220VAC - 240VAC with semi tonic frequency 50Hz in order for the appliance to operate properly.

- The voltage (230V against N) in your home network must be checked by a qualified electrician using appropriate equipment.
- The connection bridges must be placed in compliance with the network connection.

- Before connection, make sure the voltage on the identification label is consistent with the actual network voltage.
- The length of the power cord should be at least 1.5 meters; thus, the appliance can be connected before it is pushed to the wall.
- The length of the power cord should be adjusted in such a way that in case of pulling load on the cable, the ground wire is strained later than the voltage wires.

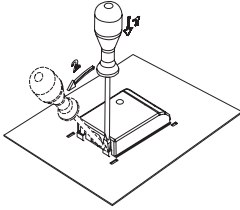

Procedure

- Use a screwdriver to open the cover of the connection terminal on the back of the appliance. Release the two clips as indicated on the cover of the connection terminal.
- The mains cord must be inserted into the strain release device which protects the cable from being pulled out. If the strain release device is not installed yet, install it in such way that it gets stuck in the connection terminal housing at one end.
- Then, connect the appliance according to the instructions indicated on the figures.
- Firmly fasten the strain release device and close the cover.

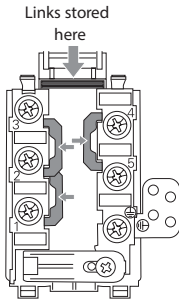

Inserting the links

Before connecting the mains cable you may have to fit the 3 links. The links are stored as shown opposite.

- Insert 1 link between positions 1 and 2.
- Insert 1 link between positions 2 and 3.
- Insert 1 link between positions 4 and 5.

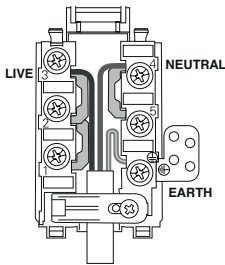

Connecting the wires

1. Connect the live (brown) wire to connection position 3.
2. Connect the neutral (blue) wire to connection position 4.
3. Connect the earth (green and yellow) wire to the connection marked ⊕. Make sure the earth wire is longer than the live and neutral wires.
4. Tighten all the connection screws.
5. Un-screw the cable clamp and place the cable under the clamp and then screw the clamp closed.
6. Close the connection box and click the lid into place.

Technical Specifications

Manufacturer	Panasonic
Model	HL-CK614SBPQ
Power Source	220-240 V, 50 Hz
Power Consumption	Maximum; 3300 W
Outside Dimensions	597 mm (W) x 565 mm (D) x 595 mm (H)
Oven Cavity Dimensions	469 mm (W) x 404 mm (D) x 341 mm (H)
Uncrated Weight	31 kg
Energy efficiency class	A
Energy consumption based on standard load - Conventional	0.91 kWh
Energy consumption based on standard load - Forced air convection	0.85 kWh
Usable Volume	65 litres
Size	Large
Time to cook standard load - Conventional	51 min
Time to cook standard load - Forced air convection	48 min
Noise	47 dB(A) re 1 pW
Stand-by power consumption	0.61 W
The area of the largest baking sheet	1400 cm ²

Specifications are subject to change without notice.

Manufactured by: Panasonic Manufacturing U.K Ltd.
Wyncliffe Road, Pentwyn Industrial Estate, Cardiff, S.Glam. CF23 7XB U.K.

Contact: Panasonic Testing Centre
Winsbergring 15, 22525 Hamburg, Germany

Panasonic Manufacturing U.K Ltd
<http://www.panasonic.net>

© Panasonic Corporation 2014

E000342W1BP